

Alldrive 10 Tonne Front tip

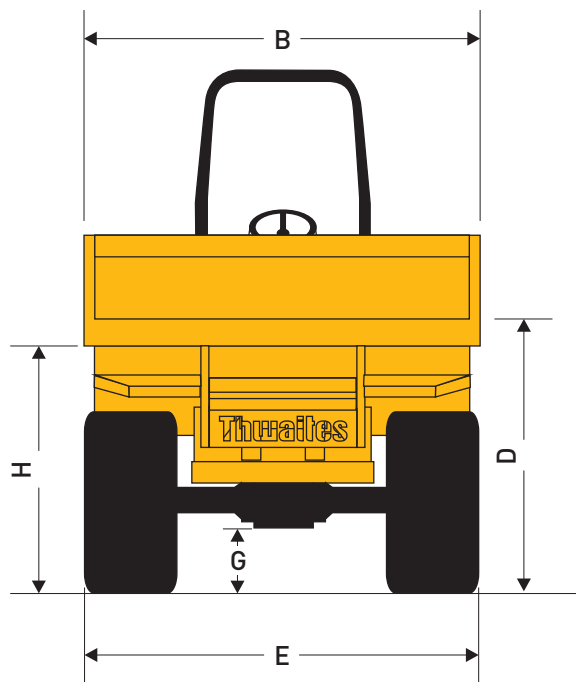
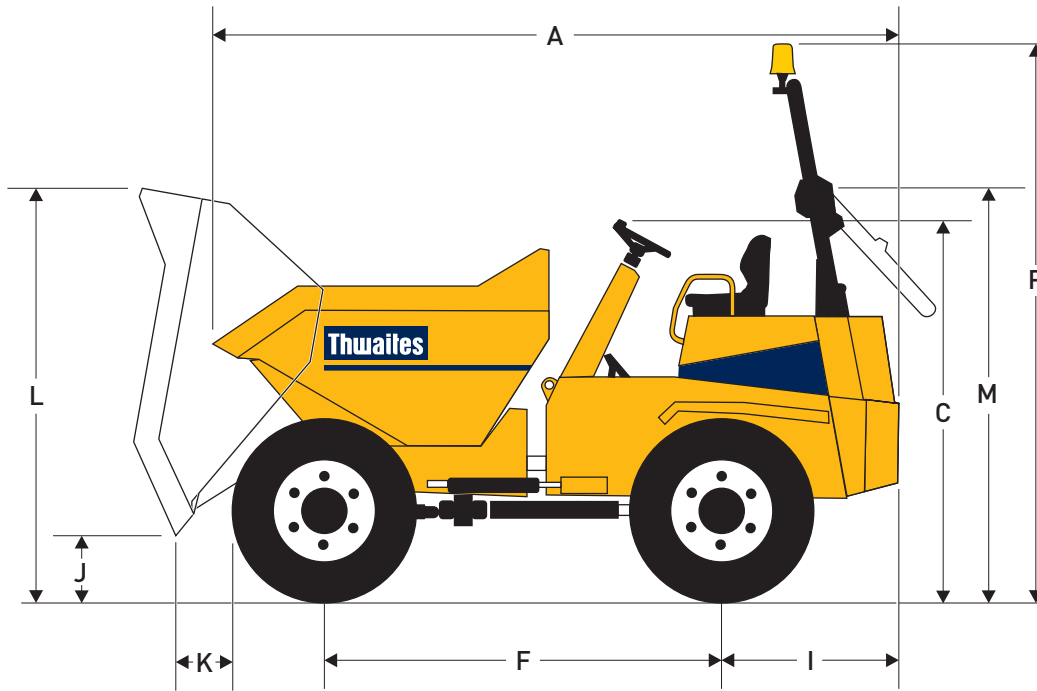

Dimensions (mm)

A	4650
B	2485
C	2540
D	1740
E	2440
F	2615
G	447
H	2135
I	1220
J	436
K	768
L	2860
M	2630
P	3415

Alldrive 10 Tonne Front tip

Capacities	Max. safe load	10000 kg
	Heaped	4700 litres
	Struck	4110 litres
	Water	2350 litres

Engine

Perkins 1100 D series, 83 kW/111 bhp (gross) at 2200 rpm, four-cylinder turbo-charged, after-cooled direct-injection diesel. Max. torque 418 Nm (308 lb ft). Hour meter, battery isolation switch and heavy-duty Power Core air cleaner positioned within the lockable engine compartment. Tier 3-/Stage IIIa-compliant.

Noise Levels

Operator's ear 84 LpA, airborne sound power level 103 LwA (to 2000/14/EC).

Transmission

Torque converter four-speed forward and reverse powershuttle transmission with column-mounted directional control lever. Heavy-duty gear driven transfer box. Optional 'Powershift' transmission with changes of speed and forward/reverse direction controlled by one column-mounted lever.

Speeds	Forward and reverse	
	1	5.4 km/h (3.1 mph)
	2	8.7 km/h (5.5 mph)
	3	16.4 km/h (10.5 mph)
	4	30.1 km/h (17.8 mph)

Tyres	500/60 x 22.5
	Track-grip tread
	12 ply

Brakes and Axles

Twin-circuit totally enclosed multiplate oil-immersed discs mounted on both axles with automatic adjustment for wear. Hand-operated parking brake on transmission disc. Heavy-duty axles with epicyclic reduction and fully floating halfshafts.

Kinglink Chassis

Front and rear chassis constructed from deep section folded steel plate, with three-point Kinglink giving centre articulation and oscillation for better stability, traction and extra safety on site. Remote greasing point provided for lubrication of top Kinglink articulation pin.

Skip

Hydraulically operated, 6 mm steel base plate. Domex 460 impact-resistant sides and top box-sections. Fully welded, mouth and sides of skip reinforced with box sections giving greater strength to minimise skip damage. No material traps.

Seating & Controls

Adjustable suspension seat includes settings for driver's weight, fore/aft movement and rear back rake. Seat is accessible from both sides. Audible warning device for handbrake in 'on' position. Electric horn. Large pedal pads with handbrake and hydraulic controls ready to hand. Super-bright warning lights for all critical functions.

Service Access

Lockable three-sided cover opens to provide easy access from ground level to engine service points, all located on the same side. Rear chassis panel can be hinged back on retainers. Additional service access door incorporates the battery. Moulded diesel and hydraulic tanks positioned low in the chassis side members, permitting access to the filler caps from ground level.

Electrics

Wiring harness contained within conduits and all electrical components water resistant to IP65/67 standards.

Steering & Hydraulics

Hydraulic priority power steering. Oil filter mounted on the top of the tank accessible from ground level. Hydraulic test point fitted as standard. Oil Cooler.

Tank Capacities	Fuel	70 litres
	Hydraulic	70 litres

Shipping Cube	34 m ³ (folded ROPS)
----------------------	---------------------------------

Unladen Weight	4780 kg (Max)
-----------------------	---------------

Clearance Diameter	14.0 m
---------------------------	--------

Towing Bracket	Standard
-----------------------	----------

ROPS

For the UK and other markets where it is a legal requirement, a folding ROPS frame is fitted as standard.

Optional Extras

Beacon. Full road lighting equipment. UK road equipment. Anti-theft device. Height-adjustable towing brackets. Reverse alarm.



Thwaites Ltd. Leamington Spa, Warwickshire CV32 7NQ, England
Tel +44 (0)1926 422471 Fax +44 (0)1926 337155
www.thwaitesdumpers.co.uk

Distributor	
PES Plant Sales	
Beare Works	
Beare	
Nr Exeter	
EX5 3JX	
01392 882220	



We reserve the right to change all specifications without prior notice. Printed in England 02/09